

Remarks

PDC	03-30
SURFACE AREA	

PRINTED COPIES ARE UNCONTROLLED

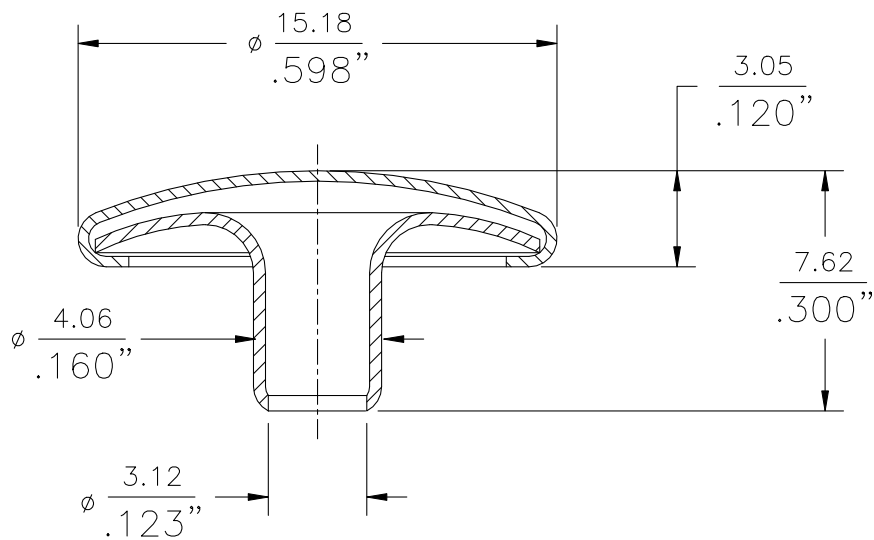
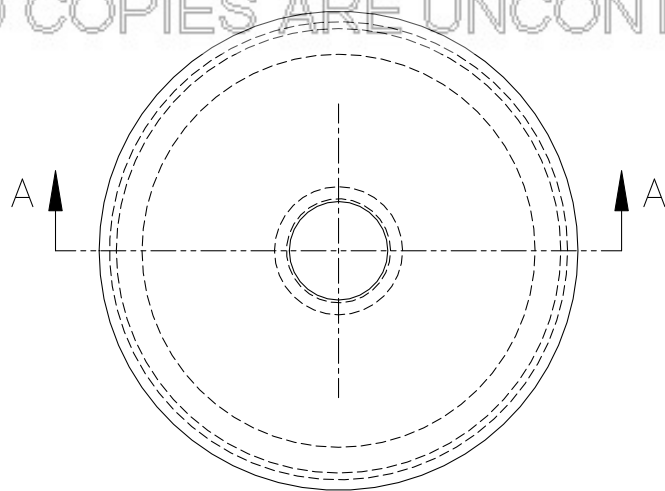

SECTION A-A

	MATERIAL	SIZE
EYELET	304 STAINLESS STEEL	0.38/.015"
CAP	304 STAINLESS STEEL	0.33/.013"

MILLIMETER ; MILLIMETER / INCH
INCH

TOLERANCES: -DECIMALS 0.13 / ±.005"

Unless otherwise specified. FRACTIONS 0.20 / ±.008"
ANGLES ±1/2°

NO.	ALTERATION	DATE	BY	APP'D



Stimpson
CO. INC.



1515 SW 13TH CT POMPANO BEACH, FL 33069

PART NAME: CAPPED EYELET

MATERIAL: SEE TABLE

SIZE: SEE TABLE

SCALE: 4:1

DEPT: MERCH.

DRAWN: L.TOLENTINO

CHECKED: B.T.

APP'D: J.C.

DATE: 11.27.17

DATE: 11.28.17

DATE: 11.28.17

PART No. SCA200

Remarks

PDC	03-31
SURFACE AREA	

PRINTED COPIES ARE UNCONTROLLED

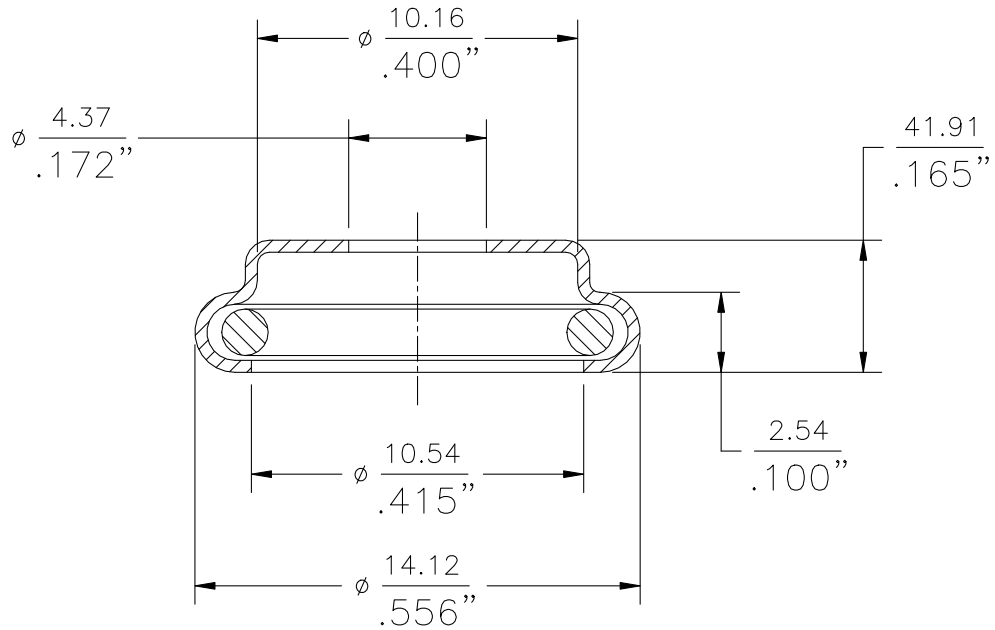
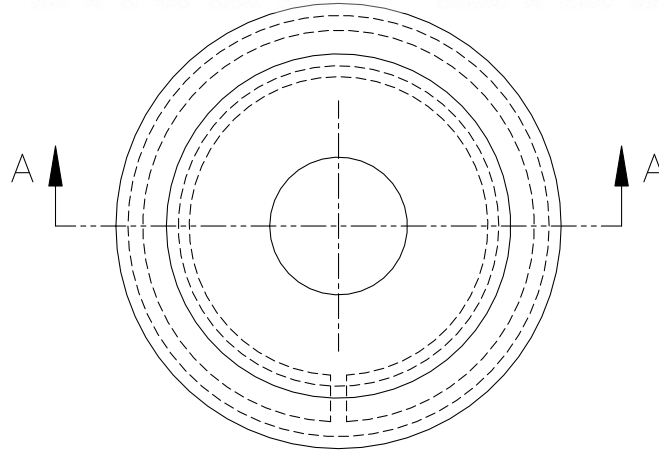

SECTION A-A

MILLIMETER / INCH ; MILLIMETER / INCH
INCH

TOLERANCES: -DECIMALS 0.13 / ±.005"
Unless otherwise specified. FRACTIONS 0.20 / ±.008"
ANGLES ±1/2°

NO.	ALTERATION	DATE	BY	APP'D



Stimpson
CO. INC.

1515 SW 13TH CT POMPANO BEACH, FL 33069

PART NAME: SOCKET

MATERIAL: 304 STAINLESS STEEL SIZE: 0.38/.015"

SCALE: 4:1 DEPT: MERCH.

DRAWN: L.TOLENTINO	CHECKED: B.T.	APP'D: J.C.
DATE: 11.27.17	DATE: 11.28.17	DATE: 11.28.17

PART No. SS0201

Remarks

PDC	03-40
SURFACE AREA	

PRINTED COPIES ARE UNCONTROLLED

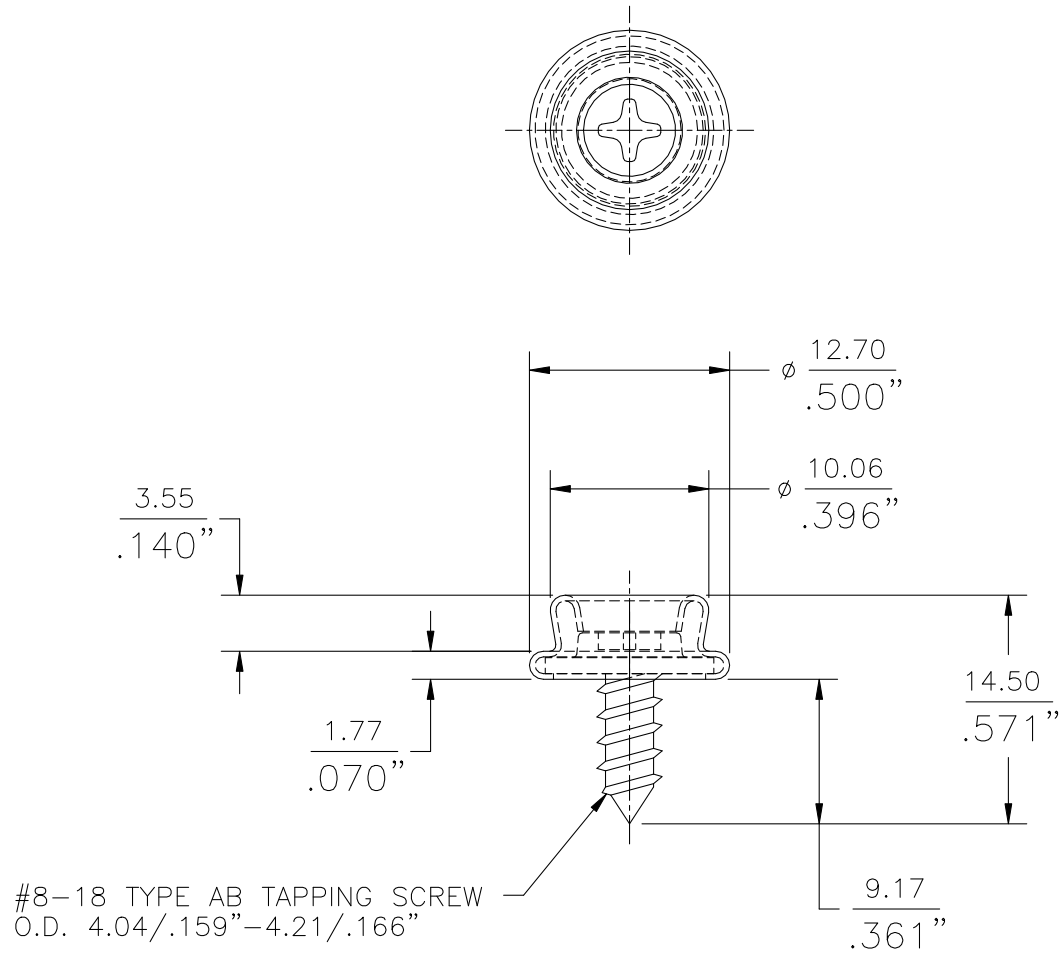

MILLIMETER / INCH ; MILLIMETER / INCH
INCH

TOLERANCES: -DECIMALS 0.13 / ±.005"
Unless otherwise specified. FRACTIONS 0.20 / ±.008"
ANGLES ±1/2°

NO.	ALTERATION	DATE	BY	APP'D



Stimpson



CO. INC.

1515 SW 13TH CT POMPANO BEACH, FL 33069

PART NAME: SCREW STUD

MATERIAL: 304 STAINLESS STEEL SIZE: 0.35 / .014"

SCALE: 2:1 DEPT: MERCH.

DRAWN: L.TOLENTINO	CHECKED: B.T.	APP'D: J.C.
DATE: 11.27.17	DATE: 11.28.17	DATE: 11.28.17

PART No. SST204